

Left Hand Opening Shown
Right Hand Opposite

See Pocket Detail Page
for Rear Pocket Option

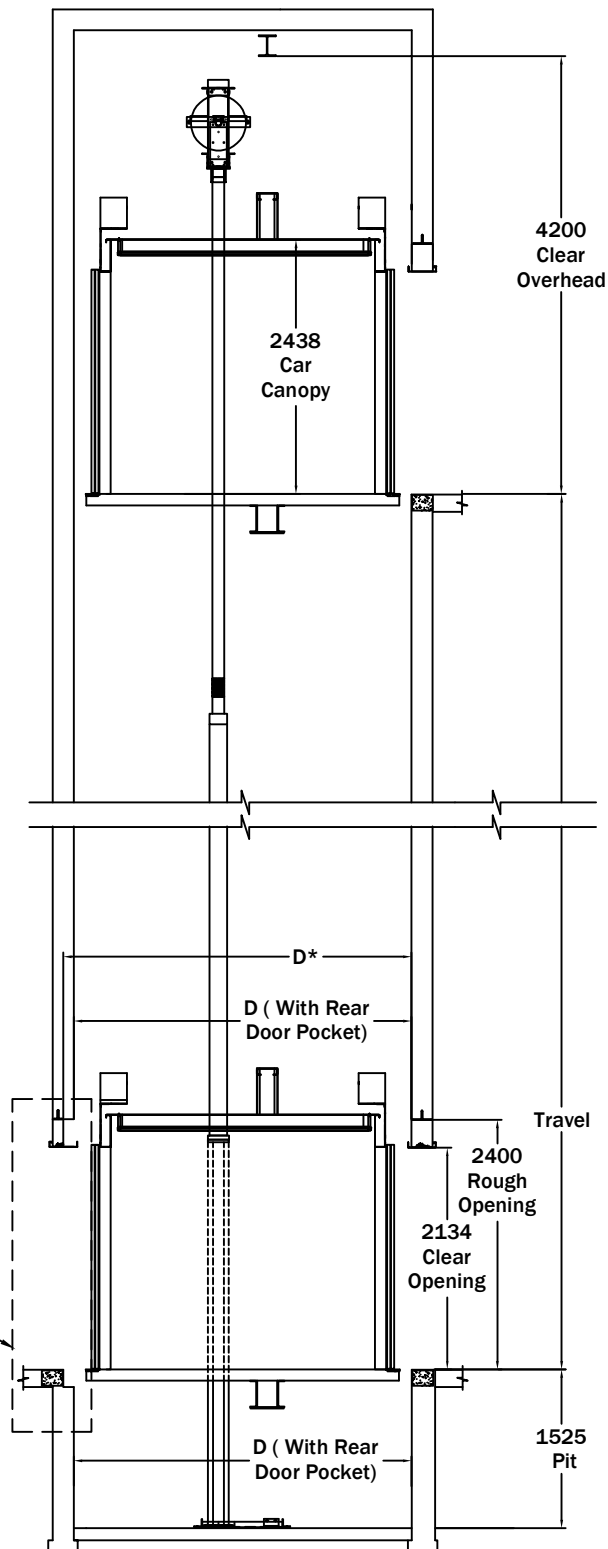

Standard Available Sizes

Capacity (kg)	W (mm)	D (mm)	D* (mm)	IW (mm)	ID (mm)	O (mm)	RO (mm)
950	2081	2514	2614	1370	1726	914	1675
1200	2118	2818	2920	1406	2032	1067	1675
1587	2322	2818	2920	1610	2032	1067	1675
1815	2438	3150	3252	1598	2364	1219	1860
2050	2438	3340	3442	1598	2554	1219	1860
2275	2696	3340	3442	1726	2554	1372	2010

- D* = D + 102 mm at Rear Entrance Only
- For Seismic Applications, Consult Delta Elevator for Increased Dimension "W"
- Clear Overhead Based Upon 2438mm Car Canopy
- Add 305mm to Clear Overhead for Every Car Canopy Increase of 152 to 305mm
- With Travel Greater than 10m, Consult Delta Elevator Regarding Design Options