

BS Touchless



The **BS Touchless** pushbutton is the perfect touch-free solution to the commonly touched elevator surface. Simply hover over the button for sensor activation.

- ✓ Dual Technology: Electromechanical contact (activated by push) and proximity sensor
- ✓ Eliminates transferring germs through touched surfaces
- ✓ Perfect retrofit product for DMG/MAD buttons
- ✓ LED Illumination available in White



General Details

- Mounting:** Frontal, by jam-nut
- Body:** AISI 303 turned stainless steel button
- Component Ordering:** Complete Assembly, BSLVF34MW.00
- Contacts:** mechanical mode: 1 contact 30V, 60mA
touchless mode: opto relay 30V, 60mA
- Wiring:** screw terminals
- Voltage:** 24V DC, stand-by 15mA, max 50mA
- Illumination:** white
- Stroke:** 0.040"
- Avg. Life:** 1,500,000 activations
- Degree of protection:** IP44, IK07
- Cleaning:** Wipe down with mild soap and a damp cloth

Physical Characteristics

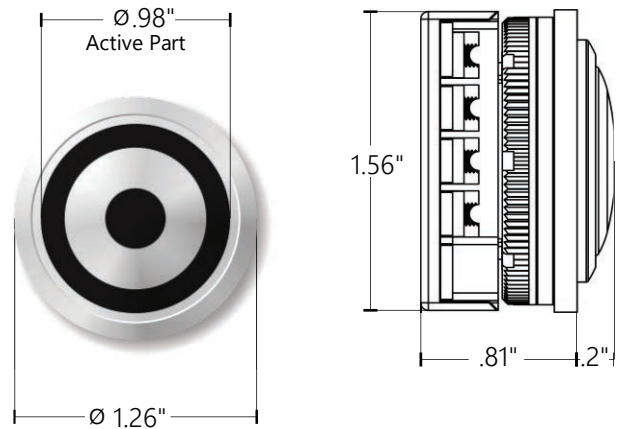

Mounting Requirements

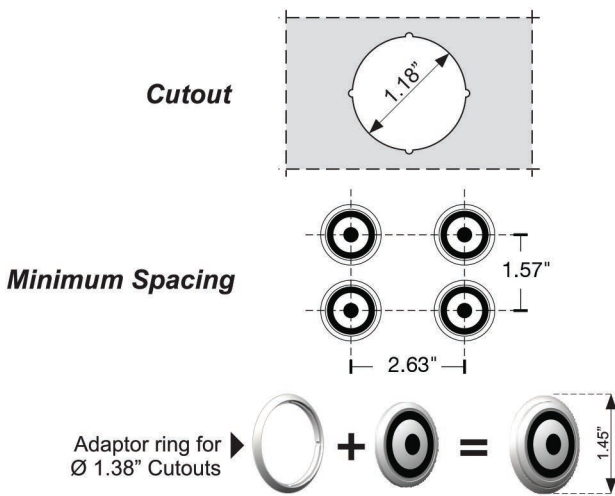

Contact Block

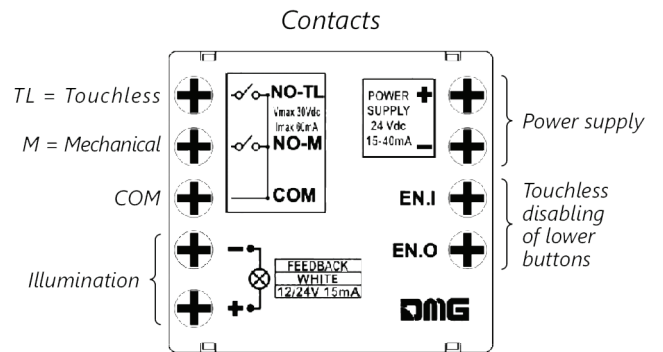

Wiring Diagram

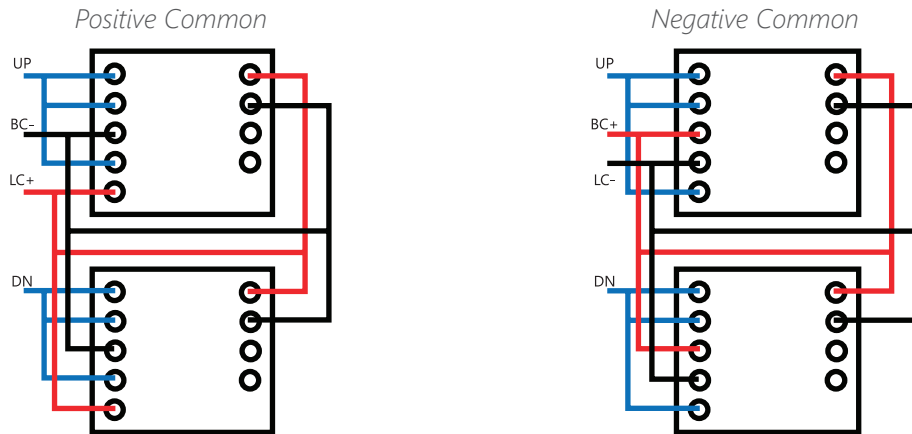

This publication is for general informational purposes only. Product design is subject to change without notice. Actual product colors and finishes may vary.

Copyright © 2020 MAD Elevator Inc.